



SUB2000™ SUB CQB™

SAFETY, INSTRUCTION & PARTS MANUAL

⚠ WARNING: Read this manual carefully before loading or using the SUB2000s.

TABLE OF CONTENTS

- A. Safety Information and Warnings.....2
- B. Overview..... 5
 - Description.....5
 - Nomenclature.....5
 - Specifications.....6
- C. Operating Instructions.....6
 - Safety.....6
 - Storage Mode.....7
 - Rotating Forend (CQB only).....9**
 - Loading Magazine(s).....9
 - Chambering a Cartridge9
 - Firing.....10
 - Unloading.....10
 - Sight Adjustment.....11
 - Removal of Thread Protector.....13
 - Removal of Front Sight Assembly13
- D. Field Strip.....15
 - Removal of Bolt Assembly.....15
 - Disassembly of Integrally Suppressed Barrel (CQB only).....17**
- E. Assembly from Field Strip.....19
 - Insertion of the Bolt Assembly.....19
 - Attaching the Stock.....20
 - Assembly of Integrally Suppressed Barrel (CQB only).....21**
- F. Cleaning and Maintenance.....22
 - Maintenance.....22
 - Lubrication.....23
 - Troubleshooting.....23
- G. Service, Repair and Limited Lifetime Warranty.....24
- H. Exploded View and Parts List.....26

A. SAFETY INFORMATION AND WARNINGS

Read this manual and the warnings contained in it before loading or using the SUB2000. This manual explains the function and the handling of the SUB2000 and warns of the potential dangers, including death or serious personal injury, that can result from the unsafe use of the SUB2000. This manual should always accompany the SUB2000 and be transferred with it if it is sold or loaned to another person.

Even if you are an experienced shooter, you must READ THIS ENTIRE MANUAL CAREFULLY before loading or firing the SUB2000. This manual gives basic instructions on the proper handling and functioning of the SUB2000. Your safety and the safety of others depends on you following the instructions and warnings in this manual and the constant use of safe firearms practices. If you are unfamiliar with firearms, take a course in the safe handling of firearms run by a qualified firearms instructor, your local gun club, or a similar qualified organization.

This manual contains several safety warnings and instructions preceded with **WARNING**, **CAUTION**, or **NOTICE**. These signal words are designed to draw your attention to important safety information. **WARNING** indicates a hazardous situation which, if not avoided, could result in death or serious injury. **CAUTION** indicates a hazardous situation, which, if not avoided, could result in minor or moderate injury. **NOTICE** addresses safety practices not related to personal injury.

WARNING Firearms can cause death or serious personal injury. Safety must be the prime consideration of anyone who handles firearms.

WARNING The SUB2000 is designed to function reliably with proper care and knowledgeable use. Do not use your SUB2000 unless you fully understand how to safely operate it.

WARNING Only safe firearm handling habits will ensure the safe use of your firearm. This is your responsibility. Accidents are the result of violating the rules of safe firearms handling noted below and common sense.

WARNING Always seek a doctor's advice if you are taking medication to be sure that you are able to shoot and handle a firearm safely. Never drink alcoholic beverages or take drugs before or while shooting. Your vision and judgment could be seriously impaired, making your firearm handling unsafe.

WARNING Always treat a firearm as though it were loaded.

WARNING Always keep the muzzle pointed in a safe direction. Never point a firearm at anyone or anything you do not intend to shoot.

WARNING Always keep your finger off the trigger and outside the trigger guard until you have made the decision to fire.

WARNING Never accept or pick up a firearm without checking the magazine and the chamber to make sure that it is unloaded.

WARNING Do not trust the extractor to remove the cartridge from the chamber. Always check to confirm that it is empty.

WARNING Always make sure the SUB2000 is unloaded, on SAFE and the action is open before handing it to another person.

WARNING Never allow a firearm to be used by individuals who are not familiar with its safe operation and rules of firearm safety.

WARNING Never alter or modify the SUB2000 because this could cause it to malfunction and create a dangerous condition.

WARNING Be sure all accessories are compatible with the firearm. Be sure all accessories are properly installed on the firearm and that the accessories do not interfere with safe operation of the firearm. Follow the instructions provide by the accessory manufacturer to the extent those instructions are not inconsistent with the warnings and instructions contained in this manual.

WARNING If the SUB2000 is dropped or forcefully struck, it could be damaged and may not function properly. Have it inspected by Kel-Tec CNC Industries, Inc. before continuing to use it.

WARNING Never load a firearm except immediately before shooting. When transporting your firearm, be sure your firearm is unloaded, on SAFE and the action is open.

WARNING Never store or transport firearms and ammunition together, keep them locked up and away from children or other unauthorized persons.

WARNING Always secure firearms from children. You are responsible for the firearm's safety and security.

CAUTION Most ammunition contains lead in the projectile and/or primer. Discharging firearms in poorly ventilated areas, cleaning firearms, or handling ammunition may result in exposure to lead and other substances known to cause birth defects, reproductive harm, and other serious physical injury. Have adequate ventilation at all times. Wash hands thoroughly after exposure.

NOTICE Some variants of this weapon may be controlled under the National Firearms Act (NFA) for suppressors, typically the CQB model.

NOTICE Suppressors, and hunting with suppressors, are not legal in some states or jurisdictions.

NOTICE Weapon laws and regulations may change overtime, which may inadvertently affect ownership or use of the weapon; it is your responsibility to understand your local and federal laws and how they apply to the possession and use of this weapon.

Before it left the factory, the SUB2000 was tested, carefully inspected, and packaged. Kel-Tec CNC Industries, Inc. cannot control what happens to the SUB2000 after it leaves the factory, therefore, carefully examine the SUB2000 when you acquire it to ensure that it is unloaded and undamaged. If you do not understand any of the warnings and instructions in this manual, have any problems operating the SUB2000, or need another copy of this manual, contact Kel-Tec CNC Industries, Inc. at:

KEL-TEC CNC INDUSTRIES INC

1505 Cox Road

Cocoa, FL 32926

Telephone Number: 321-631-0068

Toll free: 1-800-515-9983

Hours: M-F 9am-6pm EST (excluding holidays)

Website: <http://www.keltecweapons.com>

Email: customerservice@keltecweapons.com

The current version of the instruction manual can also be downloaded at:

www.keltecweapons.com/resources/downloads

B. OVERVIEW

Description

This manual is for the second generation SUB2000 weapon (serial number on receiver tube). If you have a first generation weapon (serial number on the left grip), this manual will not apply. A copy of the first generation manual is available free of charge by contacting Kel-Tec CNC Industries, Inc. (address and phone number on page #4).

The SUB2000 is a semi-automatic rifle chambered for the 9mm Luger or the .40 cal. S&W cartridge. Different versions of the SUB2000 rifle will accept most double column handgun magazines (S&W, Glock or Beretta). By rotating the barrel upwards and back, the SUB2000 rifle can instantly be reduced to a size of 16.25 x 7 inches for ease of storage.

The SUB2000 is appropriately classified as a "sub-rifle" because of its small size, light weight, and the use of a pistol cartridge. The SUB2000 rifle is intended as a compliment to the handgun with which it would have full interchangeability in ammunition and magazines.

Nomenclature

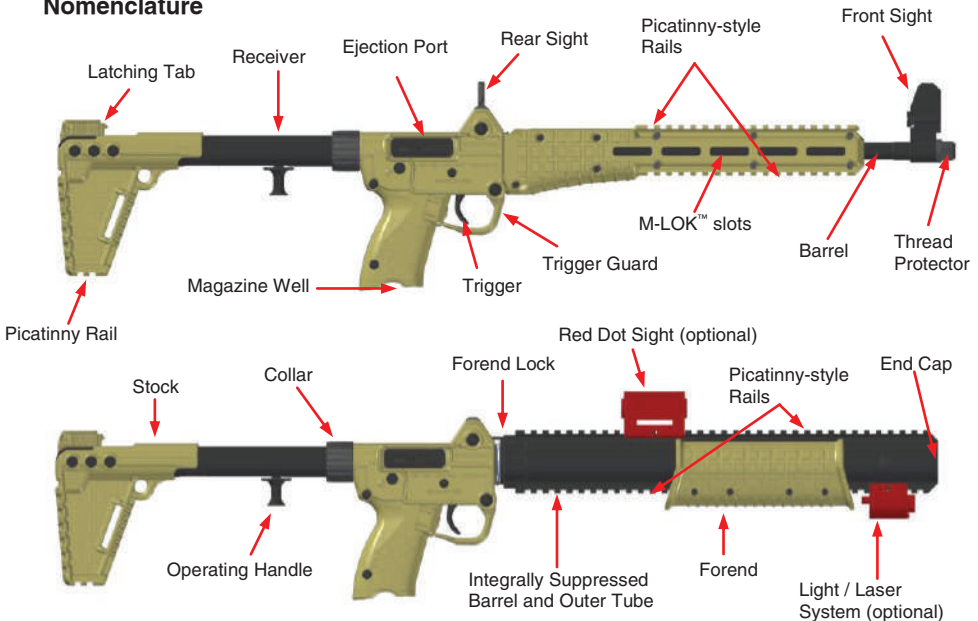

Figure B-1: Side View of SUB2000 and SUB2000 CQB (with optional accessories)

The barrel has a spring loaded collar to ensure an accurate lock to the grip, a polymer forend and a fully adjustable front sight (some variants).

Two integrated Picatinny-style rails come standard on the SUB2000 forend for mounting compatible accessories. The polymer forend also includes five mounting slots per side, configured for various M-LOK™ accessories, while other variant's forend can rotate around the bore axis to allow the sighting system rotate out of the way during storage. Always ensure accessories are compatible with this weapon, are secured to the weapon properly and do not cause any interference with the weapon or its function.

The grip is made of an impact modified glass reinforced Zytel. The front end houses a hinge block holding the barrel and rear sight. This block is securely locked in place by a rotating trigger guard. The grip rigidly attaches to the receiver by multiple lugs. The bottom forms the grip and also accepts specific magazines according to the version specified. The grip also houses the firing mechanism.

The tubular steel receiver contains the bolt assembly and is ended by the polymer stock.

The stock can be adjusted to three different positions for shooter's comfort. Each position adds approximately 5/8 of an inch to the overall length of the weapon, with a total extension of 1.25 inches in the further rearward position. The stock includes a single point sling loop attachment, a slot for adding a nylon sling loop (1.25 inch wide is ideal), and a Picatinny-style rail on the bottom for adding small accessories. The stock can be adjusted by following field stripping instructions, starting on page 15.

The heavy two-piece machined steel bolt holds the firing pin, the extractor, and has the operating handle attached on the bottom. A captive recoil spring with buffer actuates the bolt.

The firing mechanism is a conventional single action type. It has a positive disconnecter and a push-bolt safety. The hardened steel ejector is internal.

Design Features	SUB2000	SUB2000 CQB
Operating System	Blowback	
Caliber	9mm Luger or .40 cal. S&W	9mm Luger
Capacity	Varies by magazine and caliber	
Barrel Length (Standard / Export)	16.25" (412.5 mm) / 18.52" (470.5 mm)	OAL 16.2" (410mm), Rifled 4.25" (108mm)
Barrel Twist Rate (9mm / .40 cal)	1:10" / 1:16"	1:10"
Barrel Threads (9mm / .40 cal)	1/2"-28 or 9/16"-24	N/A
Trigger Pull	9 - 10 lbs (~ 4 kg)	
Accessory Mount (Top / Bottom)	Picatinny-style Rail (Forend / Stock)	
Accessory Mount (Sides)	M-LOK™ (Forend)	N/A

Dimensions and Weight		
Length (Stock Extended / Collapsed)	Approximately 30.5" (775 mm) / 29.25" (743 mm)	
Folded length (Storage Mode)	Approximately 16.25" (412.5 mm) by 7" (178 mm)	
Length of Pull (Stock to Trigger)	14.5" (368 mm) / 13.25" (337 mm)	
Max Width	At Grip 1.25" (32 mm)	At Handguard 2.35" (60mm)
Max Height	7" (178 mm)	- 8" (203mm) with red dot; -6" (152.5mm) w/o red dot
Weight (Unloaded, No Magazine)	4.25 lbs (1.9kg)	5.15 lbs (2.34kg) (no aftermarket accessories)

C. OPERATION INSTRUCTIONS

Safety

The SUB2000 features a push-bolt safety located behind the trigger on the grip assembly. The hammer must be cocked for the safety to engage. When the safety is engaged, the push-bolt safety blocks the sear from releasing and disengages the trigger bar.

For right-handed users, the safety is generally pressed with the right thumb until a noticeable “click” is heard and the red o-ring is visible on the safety, as seen in the following examples.

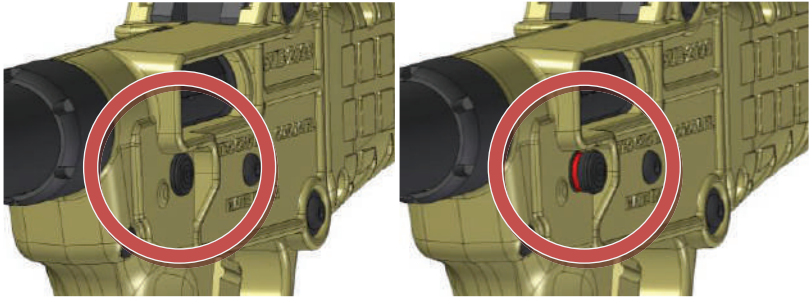

Figure C-1: Pressed to the left, SAFE Configuration; Pressed to the right, Red for FIRE

⚠ WARNING Never totally rely on a mechanical safety as it can fail or become unintentionally disengaged. A mechanical safety is not a substitute for safe firearm handling practices.

Storage Mode (Folding and unfolding Barrel Assembly)

The SUB2000 is designed to reduce its overall size down to 16.25 X 7 inches for ease of storage. This is accomplished by doing the following:

Ensure the weapon is unloaded (no magazine or ammunition in the weapon). Place the weapon in SAFE configuration. If applicable, remove any accessories on the top rail of the forend which may cause interference when folded (see page 9 for rotating forend). Rotate the trigger guard on the weapon down, away from the trigger (1). Upon doing so, the barrel assembly is free to rotate around the rear sight axis (2).

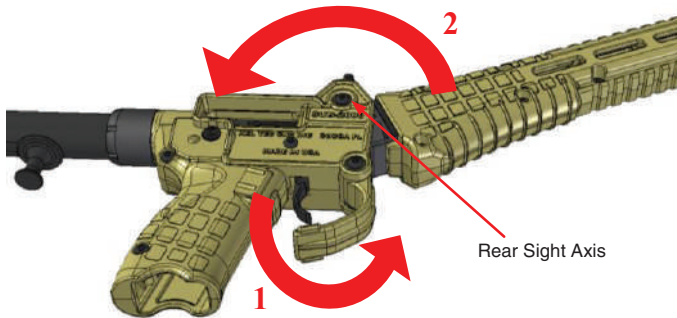

Figure C-2: Folding the Barrel Assembly

Rotate the barrel assembly until it latches into the latching tab in the buffer assembly.

⚠ CAUTION Do not release the bolt assembly from the notched, or locked back, position in the receiver tube with the barrel assembly in the storage mode; doing so could damage the receiver tube.

NOTICE The latching tab is designed to assist the barrel assembly in remaining closed in storage mode for transportation; the latching tab is **NOT** designed as a lock or safety for this weapon.

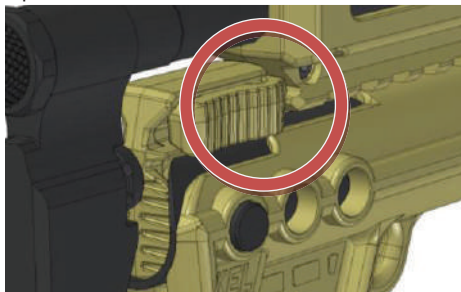

Figure C-3: Latching Tab detenting into Forend

To open the weapon from storage mode, press the latching tab rearward (away from the grip), to release the barrel assembly (1). The barrel assembly is now free to rotate to the chambering position (2).

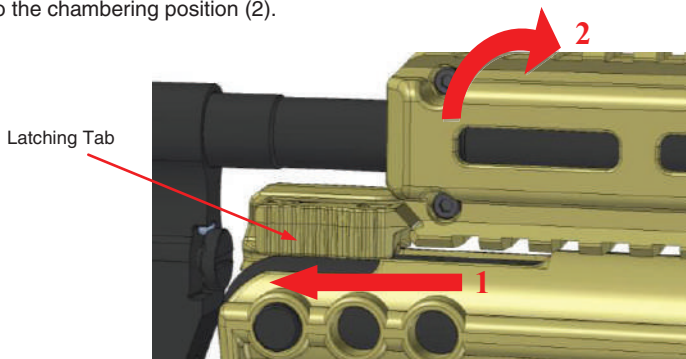

Figure C-4: Unfolding the Barrel Assembly

Upon rotating the barrel assembly down, ensure the barrel assembly positively engages into the trigger guard; there may be an auditory "snap" of the trigger guard re-engaging the barrel assembly.

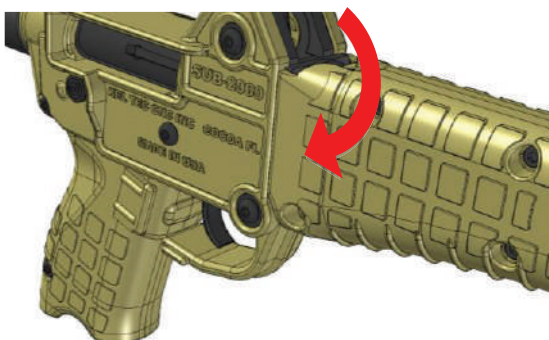

Figure C-5: Re-engage the Barrel Assembly into the Trigger Guard

Rotating Forend (CQB only). To rotate the forend on the CQB, lift the forend lock up and away from the locking surface on the forend. This allows the forend to rotate about the bore axis and move any sighting system out of the way.

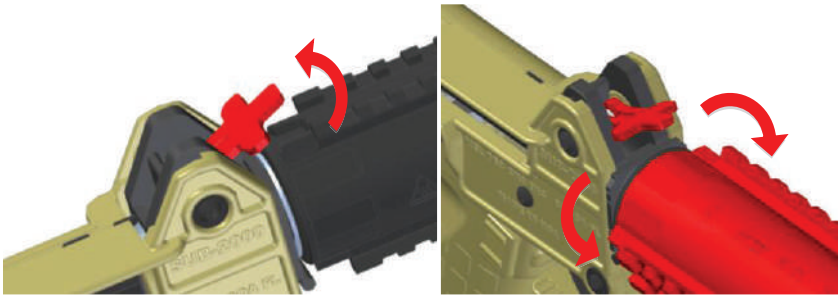

Figure C-6: Lift the Forend Lock to Rotate Forend

NOTICE A latching area is built into the handguard on the rotating forend which is designed to latch in a similar manner as the standard SUB2000 forend when folded. However, if the rail placement of the handguard is moved, or the rotating forend is not positioned correctly against the forend nut, the handguard may not latch correctly.



Figure C-7: Rotating Forend latching into the Latch Tab.

Loading the Magazine(s)

To load the magazine, fill the magazine by pressing a cartridge downward on the forward portion of the magazine, then slide the cartridge back.

Repeat the steps above for the number of cartridges you wish to load, up to the magazine capacity. Do not attempt to load your magazine with more than the specified number of cartridges because doing so can cause a feeding malfunction.

Chambering a Cartridge

Hold the rifle in one hand with the muzzle pointing in a safe direction and with your finger off the trigger and outside the trigger guard. Insert the loaded magazine into the grip until it is locked in place. Check to ensure that the magazine is secure. With your free hand, securely grab the operating handle and fully cycle the bolt back (away from the muzzle) and release. If the bolt is already locked back, pull the operating handle back a short

distance, rotate it from the machined slot and allow the bolt to carry fully forward. This strips a cartridge from the magazine and seats it in the barrel chamber.

If you wish to restore the magazine in your rifle to full capacity, press the magazine catch and remove the magazine to load the missing cartridge.

⚠ WARNING **Never load cartridges directly into the chamber.** Remember to keep your rifle pointed in a safe direction under all conditions and always keep your finger off the trigger and outside the trigger guard until ready to fire.

Firing

With the muzzle pointed in a safe direction and your finger outside the trigger guard, take aim at a safe target, disengage the safety and squeeze the trigger until the cartridge is fired. Release the trigger and you are ready to fire another cartridge. Upon firing, the bolt moves rearward, extracting and ejecting the fired cartridge and returns forward, feeding another cartridge into the chamber automatically. This sequence can be repeated until the last cartridge has been fired. The SUB2000 has no automatic bolt stop, but the bolt can be locked in the back position by rotating the operating handle into the machined slot.

Unloading

To unload the SUB2000, press in the magazine catch, remove the magazine and briskly pull the bolt back to extract the round from the chamber. Do not obstruct the ejection port and keep fingers away from the trigger and muzzle. Lock the bolt in the back position and visually inspect the chamber to make sure it is empty. To unload the magazine, push the remaining cartridges in the magazine forward and out.

⚠ WARNING Before firing the SUB2000, run a clean patch through the barrel, from the chamber end, using a cleaning rod. Repeat this procedure until the patch comes out of the barrel with no gun oil or cleaner-lubricant-preservative on it because any obstruction in the barrel could prevent the SUB2000 from firing properly and result in death or serious personal injury and/or damage to the SUB2000.

⚠ WARNING Ensure the barrel is free of obstructions prior to firing. Open the action and clear the firearm of all ammunition before checking the barrel of the unloaded firearm. Any obstruction in the barrel could prevent the SUB2000 from firing properly and result in death or serious personal injury and/or damage to the firearm.

⚠ WARNING In case of a failure to fire, continue to hold the SUB2000 pointed towards the target for at least 30 seconds. If a hangfire (slow ignition) has occurred, the bullet should fire within approximately 30 seconds. If the bullet has not fired, cycle the operating handle to its rearmost position and remove the unfired cartridge from the chamber while keeping the SUB2000 pointed in a safe direction and engage the safety. (Note: Dispose of misfired cartridges in accordance with the ammunition manufacturer's instructions).

⚠ WARNING Never use the SUB2000 if it fails to function properly, and never force the bolt forward on a jammed casing because it could cause the casing to explode or damage the SUB2000.

WARNING Never pull the trigger if the bolt does not fully close to prevent a possible out of battery firing. If this happens, unload the SUB2000 as described in this manual, examine the casing that was in the chamber, and check the chamber to ensure that there are no obstructions or debris in it.

WARNING Never discharge a firearm without proper shooting glasses and ear protection.

WARNING Never shoot until you are sure of your backstop and what lies beyond it.

WARNING Never shoot at a hard surface, such as a rock, or a liquid surface, such as water, because a bullet may ricochet and travel in any direction, striking you or someone else.

WARNING When firing on a target range, be alert and follow the range officer's commands. Always be aware of other people so that they cannot accidentally walk into the line of fire. Make sure your "audience" is always 5 feet in back of you, not next to you, when firing.

WARNING Always carry the SUB2000 unloaded with the action open while on a range until preparing to fire. Always keep the SUB2000 pointed towards the backstop when loading, firing, and unloading it.

WARNING After firing several cartridges, the exterior metal parts of the SUB2000 get very hot and can cause severe burns if touched.

Sight Adjustment

WARNING Always ensure the SUB2000 is unloaded and in SAFE configuration when adjusting the sight.

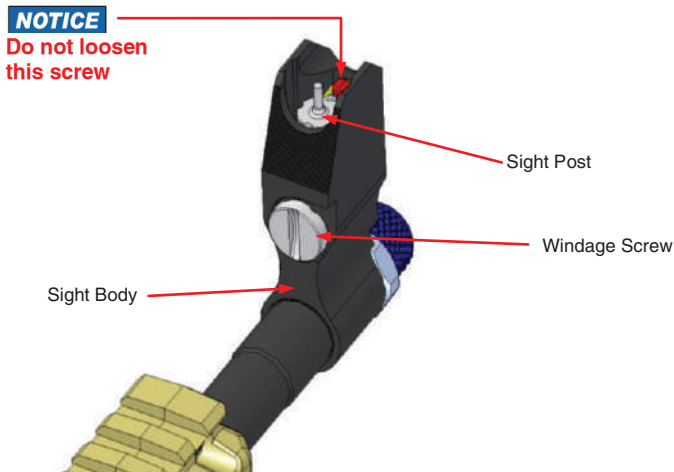
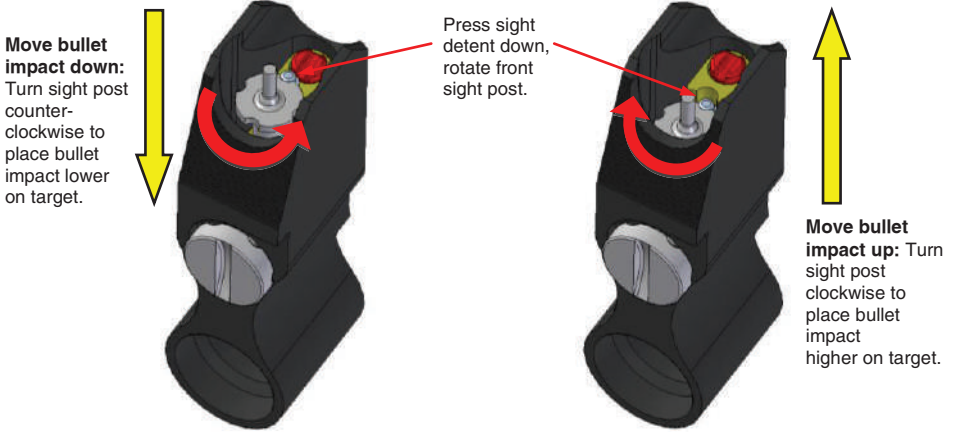
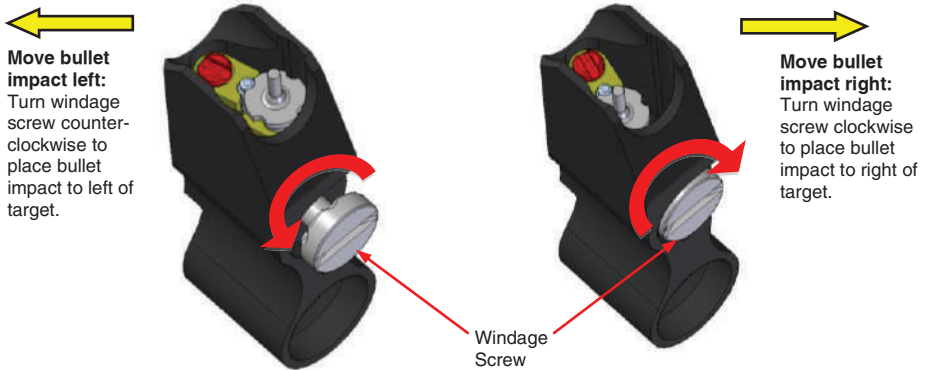

Figure C-8: Example of Front Sight

The SUB2000 is equipped with a front sight which controls both the windage and elevation of the sight alignment. The red colored screw in the following pictures is **NOT** used in the adjustment of the front sight.



The elevation adjustment on the front sight is very similar to a standard AR-15 style front sight post with four detents, or "clicks", per full turn. Each "click" is approximately one inch of bullet movement at 100 yards. The elevation is controlled by pressing the sight detent down and rotating the front sight post, either clockwise or counter-clockwise. This can be accomplished with a small hex key or with a sight adjustment tool (not included).



The windage is controlled by the windage screw which has six detents, or "clicks", per full turn. Each "click" is approximately one inch of bullet movement at 100 yards. The windage screw cams the front sight post from side-to-side. The windage screw is adjusted by using a flat tool (possibly a coin, not included) and rotating the screw either clockwise or counter-clockwise.

NOTICE Do not completely unscrew the windage screw (counter-clockwise) as there are small parts which may go missing; stop turning when the sight stops moving.

NOTICE Some variants of the SUB2000 may not ship with the above shown sight (CQB variant as an example); refer to the sighting system manuals for the sighting system which shipped with SUB2000 on windage and elevation control, if applicable.

Removal of Thread Protector (if applicable)

The thread protector on the SUB2000 is removable, if the shooter desires to replace the thread protector with a compatible accessory for the 1/2"-28 threads (9mm model) or 9/16"-24 threads (.40 cal S&W). To do so, you will need a vice, which is not included.

Ensure the weapon is unloaded (no magazine or ammunition in the weapon) and in SAFE configuration. Lock the weapon securely down by placing the front sight assembly in a vice.

NOTICE Place some type of cloth or plastic protector around the front sight so as to not damage the finish; do **NOT** clamp directly onto the polymer components as they may become damaged or loose. Turn the thread protector counter-clockwise to loosen and remove the thread protector. Once removed, a compatible accessory for the specific caliber thread can be added to the exposed barrel threads. Maximum torque on barrel is 10 ft-lbs. Do **NOT** tighten accessories onto barrel beyond this torque; doing so may damage weapon.

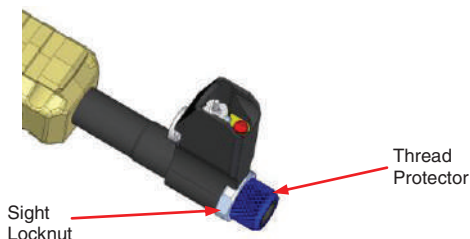

Figure C-9: Example of Thread Protector

Removal of Front Sight (Optional)

The front sight is also removable if the shooter desires to remove the front sight or replace the forend with any aftermarket accessories, which requires the front sight removal for installation. To do so, you will need a vice, an adjustable wrench (or 3/4" socket with breaker bar), and a heat gun (optional); these tools are not included.

Ensure the weapon is unloaded (no magazine or ammunition in the weapon) and in SAFE configuration. Lock the weapon securely down by placing the front sight assembly in a vice.

NOTICE Place some type of cloth or plastic protector around the front sight so as to not damage the finish; do **NOT** clamp directly onto the polymer components as they may become damaged or loose. Turn the thread protector counter-clockwise to loosen (unless already removed) and remove the thread protector.

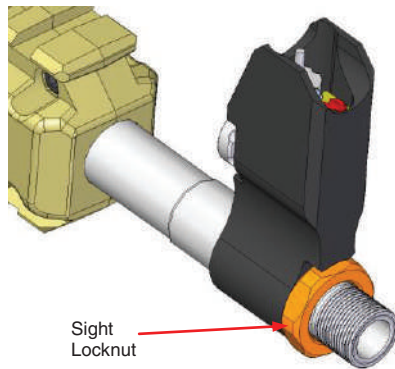

Figure C-10: Example of Front Sight with no Thread Protector

Add adjustable wrench (or $\frac{3}{4}$ " socket and breaker bar) to sight locknut and loosen sight locknut. This was assembled with approximately 10 ft-lbs of torque so it may require some force to remove. Once the sight locknut is loosened, it can be removed by hand.

Once the sight locknut is removed, rotate the front sight counter-clockwise until the front sight is removed from the barrel assembly; this will take several rotations to remove the sight. This also may require a small amount of heat to loosen any thread-locking compounds which were used during assembly.

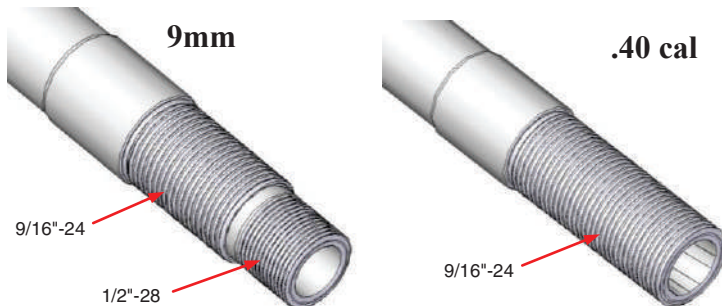

Figure C-11: Different threads on different models.

Once the front sight is removed, there are two exposed threads on the 9mm model and one exposed thread on the .40 cal S&W model for attaching caliber appropriate accessories (Figure C-11). Always ensure accessories are compatible with this weapon, are secured to the weapon properly and do not cause any interference with the weapon or its function.

To add the front sight back to weapon, you will need the sight, the sight locknut, the thread protector, a vice, adjustable wrench (or $\frac{3}{4}$ " socket and breaker bar), small bubble level, and thread-locking compound (optional); these tools are not included.

Ensure the weapon is unloaded (no magazine or ammunition in the weapon) and in SAFE configuration. Lock the weapon securely down by placing the barrel assembly in a vice so the weapon will not move.

NOTICE Place some type of cloth or plastic protector around the metal components so as to not damage the finish; do **NOT** clamp directly onto the polymer components as they may become damaged or loose.

Add no more than three drops of thread-locking compound to the exposed 9/16"-24 threads on the barrel, furthest threads away from the muzzle end of the barrel. This step is not required but can assist with locking the sight in place. Rotate the sight onto the barrel until the sight stops moving. There should be approximately 7/16" of exposed threads at the muzzle end of the barrel. Add the bubble level to the top of the sight to check the level compared to the weapon and adjust the sight as needed. When the sight is level to the weapon, add the sight locknut to the exposed 9/16"-24 threads in front of the sight. Add the wrench to the sight locknut and torque it into the sight to approximately 10 ft-lbs or until it stops moving. Add the thread protector to the exposed thread end of the barrel. Tighten the thread protector until it bottoms out against the sight locknut.

D. FIELD STRIP

For regular maintenance of the SUB2000, it will be necessary that you become familiar with field stripping the weapon (disassembly). The following sections should be followed in sequential order and continued as needed depending on desired maintenance.

⚠ WARNING If the SUB2000 has been fired, wait a sufficient amount of time for the components to cool before attempting field stripping; failure to do so may result in burns.

⚠ WARNING Never rely on your memory to determine whether the weapon is loaded or unloaded. Always open the action and then visually and physically (with your finger) check to make sure there is not a cartridge in the chamber.

⚠ WARNING Never alter or modify the SUB2000 because this could cause it to malfunction and create a dangerous condition.

⚠ WARNING Always wear safety glasses when disassembling the SUB2000 to protect your eyes from components that are under pressure, such as springs.

NOTICE The stock pin is **NOT** held captive in the stock once it is removed. **DO NOT LOSE THE STOCK PIN.**

Rotate the barrel assembly into the forward position (if the barrel assembly was folded) and make sure the SUB2000 rifle is unloaded. Make sure the bolt assembly is in the forward (closed) position, hammer is cocked and push-bolt safety is engaged.

Press the buffer assembly in, towards the front of the weapon. The buffer assembly will move forward approximately 3/32" before bottoming out on the stock pin (1). Release a small amount of tension on the buffer assembly (away from the front of the weapon) so the stock pin can begin to be removed (2). This is needed as the stock pin is held captive by the buffer assembly.

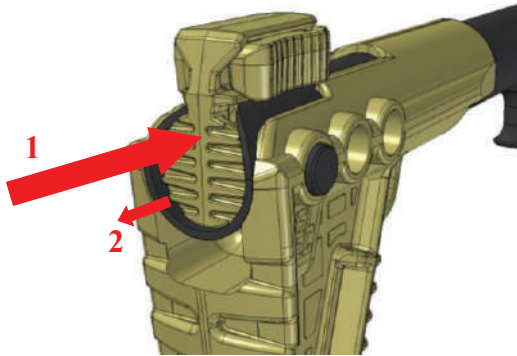

Figure D-1: Press in Buffer Assembly

With a cartridge or other pointed object, press the stock pin from either side until the stock pin is removed.

CAUTION

The buffer assembly is under tension from the recoil spring. Keep positive contact with the buffer assembly while the stock pin is removed as parts may fly loose.

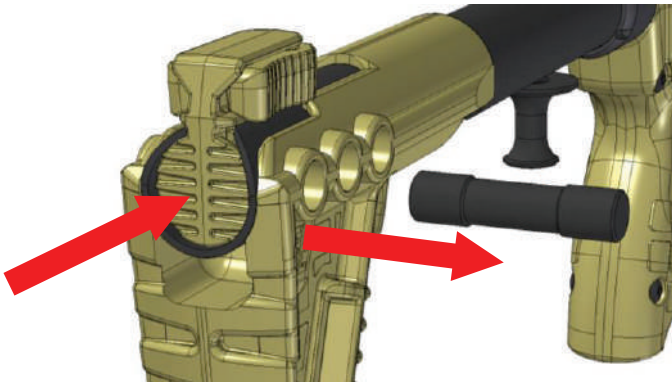

Figure D-2: Removal of Stock Pin

Place the stock pin in a safe location. Remove buffer assembly and place it in a safe location.

Pull the bolt assembly back by the operating handle and pull out the recoil spring. The operating handle can now be pulled out downwards, allowing the bolt assembly to slide out of the rear of the receiver tube. The bolt assembly can be separated by lifting the bolt head off of the bolt. The stock can be removed or adjusted in this position as well, once the stock pin has been removed.

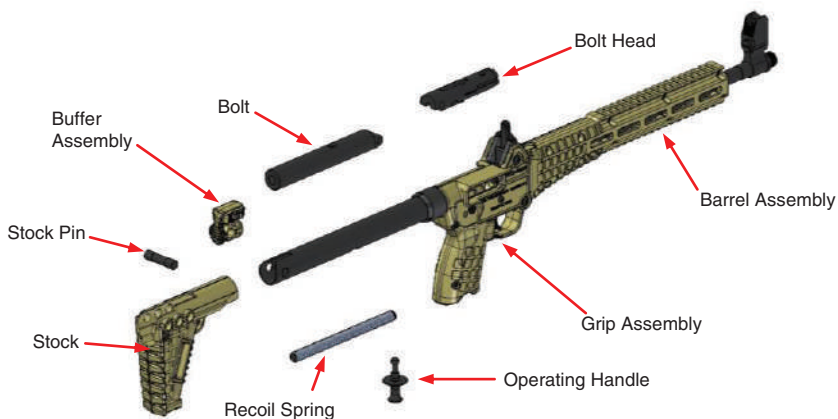

Figure D-3: SUB2000 General Field Strip

The barrel assembly can be rotated up for cleaning or inspection at this point; further field stripping is not required for normal operation.

NOTICE Do not release the hammer with the bolt assembly removed. This will make the SUB2000 rifle inoperable.

NOTICE We strongly discourage unscrewing the collar or barrel. These parts are assembled with special tools and compounds and may cause damage if removed improperly.

Disassembly of Integrally Suppressed Barrel (CQB ONLY)

WARNING The baffles for the suppressor must be disassembled and re-assembled as described below. Failure to do so may result in serious personal injury or damage to the SUB2000.

Using the supplied wrench or a flat tool, rotate the end cap counter-clockwise to loosen and remove the end cap from the barrel tube.

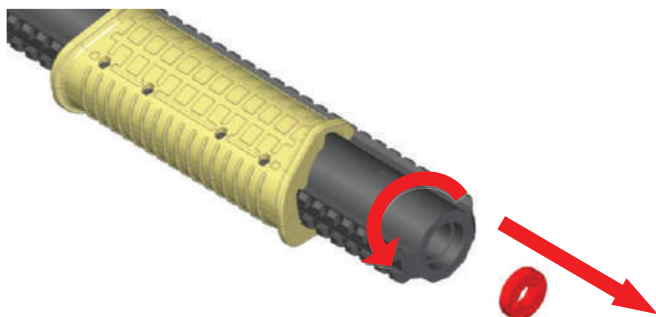

Figure D-4: Removal of End Cap

Carefully remove the first set of baffles from the suppressor. These baffles are aluminum and longer in length and lighter overall.

CAUTION Do **NOT** submerge the weapon system into any ultrasonic cleaner.

NOTICE The baffles may be snug or a tight fit in the barrel tube; adding some cleaner-lubricant-protectant to the baffles may assist in loosening them from any carbon build-up.

NOTICE The parts list (page 28) for the weapon has the part count for the total number of baffles in the assembly.

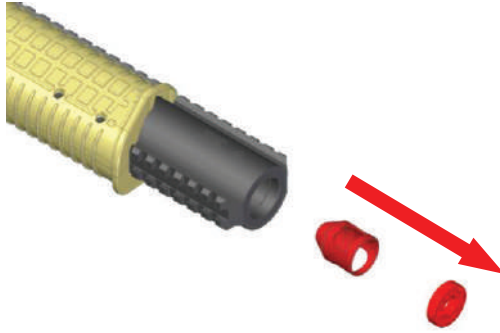

Figure D-5: Removal of Aluminum Baffles

Carefully remove the second set of baffles from the suppressor. These baffles are steel and are shorter in length and heavier than the aluminum baffles.

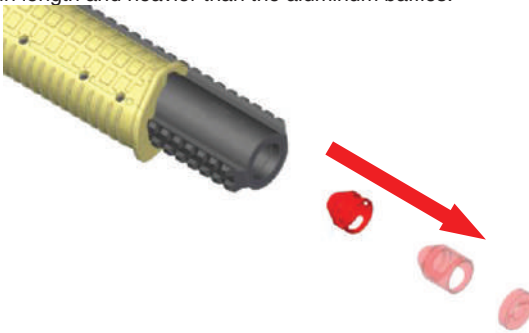

Figure D-6: Removal of Steel and Aluminum Baffles

Unscrew the outer tube until it is able to be slid forward from the attached threads so the blast chamber is exposed on the barrel tube. Ensure all baffles are removed from the barrel tube by looking through the slots.

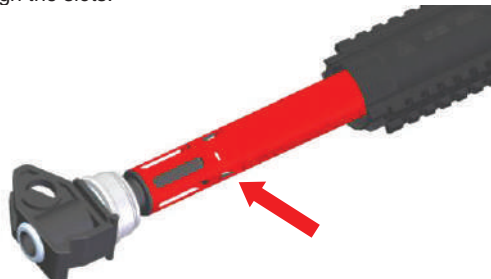

Figure D-7: View through the slots to ensure Baffles are removed



The outer tube is **NOT** fully removable from the barrel tube. The outer tube should stop near the end of the barrel tube during disassembly.

E. ASSEMBLY FROM FIELD STRIP

Rotate the barrel assembly into the forward position (if the barrel assembly was folded). Slide the bolt and bolt head together by aligning the machined slots in the parts.

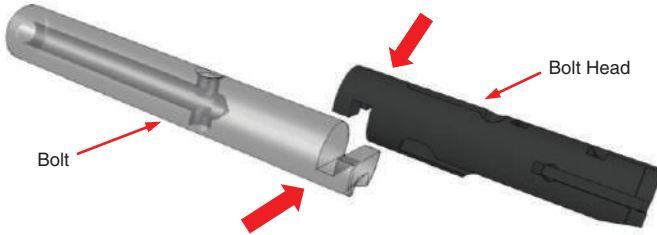

Figure E-1: Assembly of the Bolt and Bolt Head

Insert the combined bolt and bolt head into the receiver. Line up the operating handle hole with the operating handle slot below and then fully insert the operating handle (1). Put the recoil spring into the bolt (2), then slide the bolt assembly forward (3).



Figure E-2: Bolt Assembly in Receiver with Recoil Spring

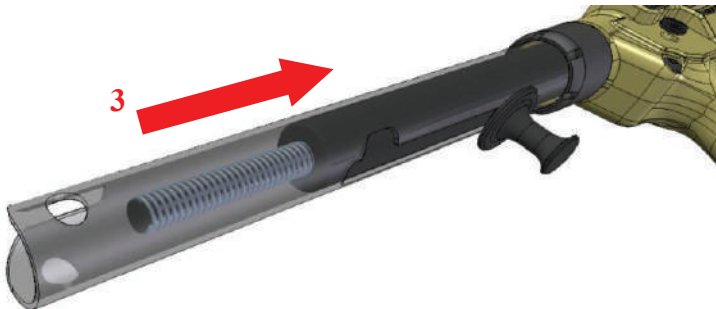

Figure E-3: Sliding Bolt Assembly forward

Add the stock to the receiver and set the stock position. Position 1 is the shortest overall length of the weapon. Position 2 adds 5/8" to the overall length and position 3 adds 1.25" to the overall length of the weapon.



Figure E-4: Attaching the Stock

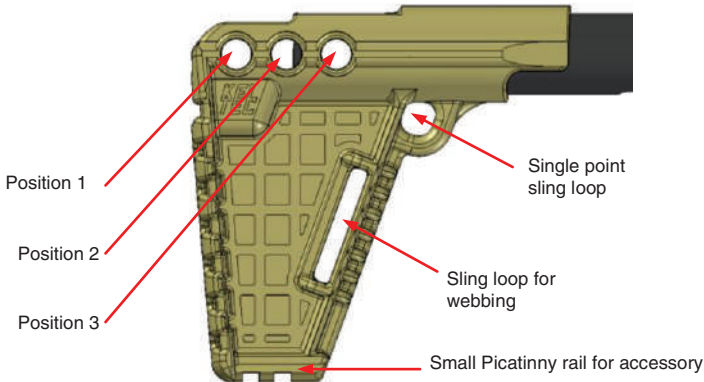

Figure E-5: Explanation of Stock

After aligning the stock to the desired position, add the buffer assembly. Figure E-6 shows the stock in Position 3.

NOTICE The bolt assembly may need to be pressed towards the rear of the weapon slightly to make certain that the recoil spring and buffer assembly are aligned when inserting the buffer assembly. After doing so, press the buffer assembly towards the front of the weapon.

CAUTION The buffer assembly is under tension from the recoil spring.

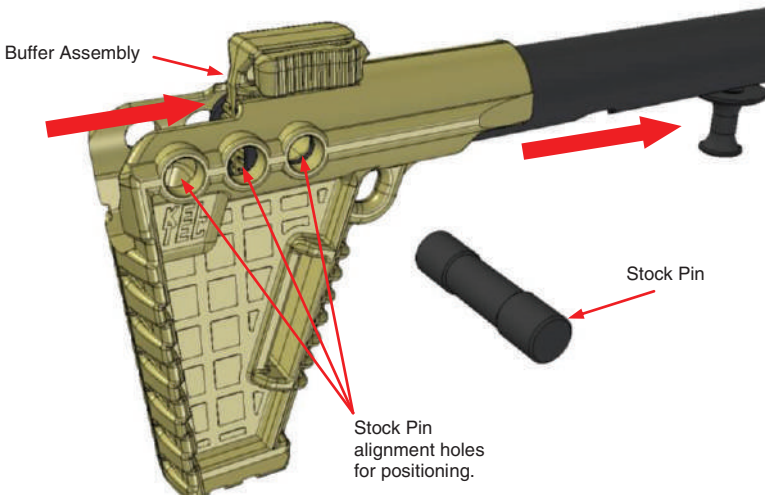

Figure E-6: Insert the Stock Pin into the Assembly

Line up the slot in the buffer assembly with the desired stock position and receiver. Push the stock pin completely in, which may take some adjusting of the parts for complete alignment (1). After the stock pin is pressed in, release the tension on the buffer assembly (2) and cycle the bolt assembly a few times to check the action (3).

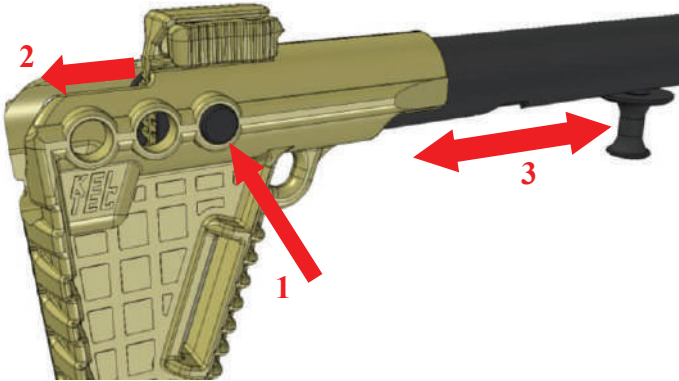

Figure E-7: Testing Function of Weapon

Assembly of Integrally Suppressed Barrel (CQB ONLY)



The baffles are only designed to assemble in one direction, with the cone of the baffle facing towards the chamber end of the barrel in order to stack properly.

For assembly, ensure the outer tube is threaded onto the forend nut until it nearly bottoms out on the forend nut's threads (1). The steel baffles are installed first into the barrel tube (2), followed by the aluminum baffles (3).

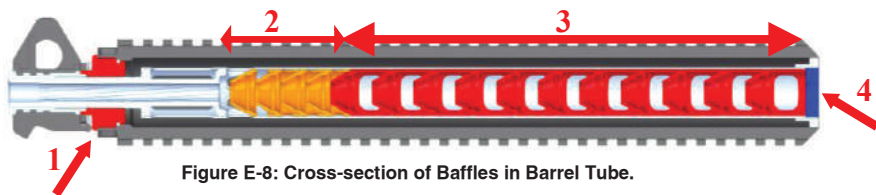

Figure E-8: Cross-section of Baffles in Barrel Tube.

Once the baffles are properly installed into the barrel tube, thread the end cap onto the barrel tube (4). Ensure the end cap is hand tight with the supplied wrench or tool.

Fold the weapon and visually inspect the bore line from the barrel's chamber end to ensure there are no obstructions in the barrel or suppressor.

WARNING Ensure the end cap on the CQB is properly secured to the threads in the barrel tube and is hand-tight.

F. CLEANING AND MAINTENANCE

Maintenance

WARNING Remove the magazine, verify that the chamber is unloaded, and remove all live ammunition from the area before working on the SUB2000 to reduce the chance of a negligent discharge.

WARNING Always wear safety glasses when cleaning the SUB2000 to protect your eyes from cleaning materials.

WARNING Always make sure that no ammunition is located in the area where you clean the SUB2000. Cleaning solvents can affect the primer and powder in ammunition and cause it to malfunction. This could result in a bullet being pushed into the barrel of the SUB2000 and getting stuck. Firing another cartridge with a bullet stuck in the barrel could cause the barrel to burst and result in death or serious personal injury and/or damage to the SUB2000.

WARNING If the SUB2000 has been fired, wait a sufficient amount of time for the components to cool before attempting disassembly, failure to do so may result in burns.

Your SUB2000 is a precision instrument and will provide a lifetime of faithful service if it is properly cleaned and maintained. It is recommended that you clean your SUB2000 after every shooting session or more frequently if needed. Be sure to unload your SUB2000 before performing any cleaning or maintenance procedures.

NOTICE Cleaning the suppressor and components should be completed every 500 – 1000 rounds, or as needed.

NOTICE Only use commercially available gun solvent and gun oil or a cleaner-lubricant-preservative. Use of improper cleaning fluids could damage the SUB2000 and void your warranty.

Lubrication

After cleaning the entire gun, use a cloth to apply a light coating of high quality gun oil to all internal and external metal surfaces and wipe clean.

Manually cycle the action back and forth to check the function of the firearm. If any parts are damaged or badly worn or the firearm does not work correctly, the firearm should not be fired and should be returned to KelTec for servicing immediately.



WARNING Discharging a firearm with oil, grease, or any other material even partially obstructing the bore could result in serious injury or death and serious damage to your firearm.

Troubleshooting

Proper function of your SUB2000 is directly related to maintenance and care, and to the ammunition you use. Some of the more common types of malfunctions which may occur are as follows:

Misfire: Failure of the cartridge to ignite when the hammer falls. If this occurs, keep the firearm pointed in a safe direction, wait 30 seconds to avoid hangfires. Remove the magazine from the weapon by pressing the magazine release and ensuring the magazine ejects from the weapon. Cycle the bolt assembly manually to eject the cartridge. Place the weapon in SAFE configuration, fold the barrel assembly and check for any obstruction in the barrel. The most common cause of misfire is faulty ammunition.

Failure to Feed: This occurs when a cartridge has been fed from a magazine but not fully chambered. If this occurs, keep the firearm pointed in a safe direction. Remove the magazine and the cartridge from the ejection port of the weapon. Inspect the cartridge and magazine for any issues. If necessary, change the magazine. The most common causes are dirt or foreign objects impeding the magazine follower; improperly crimped cartridges are another cause.

Failure to Eject or Extract: A fired cartridge is not fully extracted from the chamber or ejected from the rifle. If this occurs, keep the firearm pointed in a safe direction, remove the magazine and the cartridge from the ejection port of the weapon. If necessary, change the magazine. The most common causes are a damaged extractor, ejector or ammunition; improperly loaded or sized cartridges can cause this also.

If any of the above problems are not solved by cleaning or by use of other brands of ammunition, stop firing, unload and return the weapon to our service department.

G. SERVICE, REPAIR, AND WARRANTY



Always make sure the SUB2000 is unloaded before sending it in for service.



For the SUB2000 CQB, DO NOT ship the item without first contacting KelTec's service department. Furthermore DO NOT ship without a copy of the approved BATF form.

If your SUB2000 ever requires adjustment, refinishing or repair, it should be returned to Kel-Tec CNC Industries, Inc.'s service department. The unloaded firearm should be sent with prepaid shipping to:

Kel-Tec CNC Industries, Inc.
Service Department
1505 Cox Road
Cocoa, FL 32926

Contact your chosen carrier to determine its requirements for shipping firearms. In certain states, your firearm may have to be returned to you through a local federally licensed firearms dealer. Be sure to securely package your firearm and insure it for its full value because Kel-Tec CNC Industries, Inc. is not responsible for firearms lost or damaged during shipment.

To ensure prompt service and handling, include a brief letter including your name, address, telephone number, the serial number of your SUB2000, and what you would like to be done with it, or the issue that you would like to be addressed. No return authorization number is required. Once your firearm has been received, we will provide a quotation of all charges (unless the repairs are covered by the warranty) and will not begin work until we receive your approval. Charges for adjustments, refinishing, and repairs are payable by money orders, Master Card, Visa, and American Express. No COD or personal checks are accepted.

LIMITED LIFETIME WARRANTY

Subject to the terms, conditions and limitations outlined below, Kel-Tec CNC Industries, Inc. guarantees your SUB2000 against defects in materials and workmanship for the lifetime of the original consumer purchaser.

To make a claim under this warranty, return your SUB2000 pursuant to the instructions above and include a copy of a bill of sale in your name, or a copy of the 4473 form, showing that you are the original consumer purchaser. For repairs that are covered by the warranty, Kel-Tec CNC Industries, Inc. will pay the transportation and insurance charges to return your SUB2000.

LIMITATIONS OF WARRANTY

The warranty will be void if any of the following occur:

- (1) the instructions in the Instruction Manual are not followed;
- (2) the SUB2000 or any of its parts are altered or modified from their original state;
- (3) damage is caused by misuse, abuse or improper maintenance; or
- (4) the SUB2000 is disassembled beyond the instructions in the Instruction Manual.

There are no warranties which extend beyond the description on the face hereof.

The sole and exclusive remedy pursuant to this warranty is the repair or replacement of the SUB2000, at the sole discretion of Kel-Tec CNC Industries, Inc.

The implied warranties of merchantability and fitness for a particular purpose are expressly disclaimed.

All disclaimers and limitations of liability shall still apply even if the limited remedy of repair and replacement fails of its essential purpose.

In states where permitted, Kel-Tec CNC Industries, Inc. assumes no liability for incidental or consequential damage or for incidental expenses.

Any action against Kel-Tec CNC Industries, Inc. based on an alleged breach of this warranty must be brought within one (1) year of the claimed breach.

Kel-Tec CNC Industries, Inc.'s liability for breach of warranty shall be limited to repair or replacement of the SUB2000, at the sole discretion of Kel-Tec CNC Industries, Inc.

The SUB2000 is a dangerous weapon. The purchaser assumes all liability resulting from unsafe handling or any action that constitutes a violation of any applicable laws or regulations. KelTec will not be responsible for injuries or damages resulting from careless handling, unauthorized or unsafe adjustments or modifications, the use of non-standard, defective, or improper ammunition, the use of incompatible or improperly installed accessories, corrosion, neglect, fire damage, water damage, theft, abuse, ordinary wear and tear, or unreasonable use of the SUB2000. Under no circumstances shall KelTec be responsible for incidental or consequential damages with respect to economic loss or injury or property damage, whether as a result of breach of express or implied warranty, negligence or otherwise.



SUB2

* PARTS #410L, #410R, #205 ARE MODEL SPECIFIC FOR REPLACEMENT

** PARTS #100-9, #100-40, #151-9, #151-40, #532-9, #532-40 ARE CALIBER SPECIFIC FOR REPLACEMENT

*** PART #310 IS CALIBER AND MODEL SPECIFIC FOR REPLACEMENT



- 100-40 BARREL (.40 CAL S&W)
- 100-9 BARREL (9MM)
- 102 HINGE
- 105 WASHER
- 121 FEEDRAMPS
- 144 OPERATING HANDLE
- 151-40 BOLT HEAD (.40 CAL S&W)
- 151-9 BOLT HEAD (9MM)
- 152 BOLT
- 158 REAR SIGHT
- 164 WINDAGE DETENT
- 165 WINDAGE DETENT SPRING
- 170 FIRING PIN
- 172 FIRING PIN SPRING
- 180 EXTRACTOR
- 182 EXTRACTOR SPRING

- 190 RECOIL SPRING
- 191 RECOIL SPRING LUG
- 192 RECOIL SPRING GUIDE
- 205 MAG CATCH
- 207 RED O'RING
- 208 MAG CATCH SPRING
- 222 BUFFER
- 225 LATCHING TAB
- 246 RECEIVER (EXCHANGE ONLY)
- 247 UPPER FEEDRAMPS
- 248 EJECTOR
- 250 TRIGGER GUARD SPRING
- 251 TRIGGER GUARD
- 252 TRIGGER
- 254 TRIGGER AXIS
- 255 TRIGGER BAR PIN

- 256 TRIGGER SPRING
- 260 TRIGGER BAR
- 264 SAFETY SPRING
- 266 SAFETY
- 267 SEAR AXIS
- 269 SAFETY PIN
- 270 SEAR
- 271 HAMMER
- 272 SEAR SPRING
- 273 HAMMER BUSHING
- 275 HAMMER SPRING
- 276 HAMMER AXIS
- 309 LATCH SPRING
- 310 GENERIC MAGAZINE
- 315 E-CLIP
- 355 FRONT SIGHT PIN

2000®

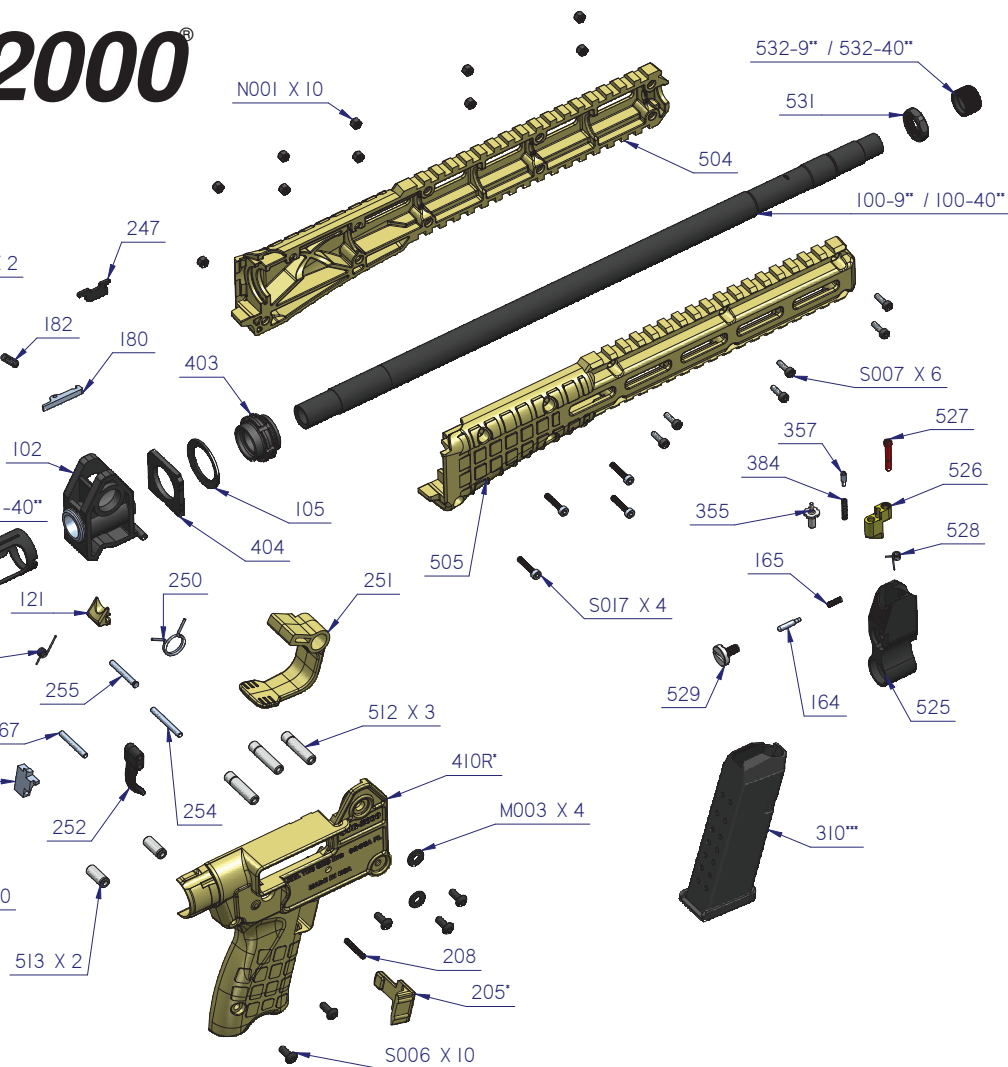

G

G

NG

G

ZINE

OST

357	FRONT SIGHT DETENT PIN	527	SHOULDER BOLT
384	FRONT SIGHT DETENT PIN SPRING	528	WINDAGE SPRING
403	LOCKNUT	529	WINDAGE SCREW
404	LOCKNUT WASHER	531	SIGHT LOCKNUT
410L	GRIP LEFT	532-40	THREAD PROTECTOR (.40 CAL S&W)
410R	GRIP RIGHT	532-9	THREAD PROTECTOR (9MM)
411	GRIP SNAP	M003	WASHER
448	COLLAR	N001	M3 NUT
500	STOCK	P021	RETAINING PIN
502	STOCK PIN	S006	M4 X 10 BHS
504	FOREND LEFT	S007	M3 X 10 SHS
505	FOREND RIGHT	S017	M3 X16 SHS
512	RECEIVER GRIP PIN LONG		
513	RECEIVER GRIP PIN SHORT		
525	SIGHT BODY		
526	SIGHT HOLDER		

NOTE:
Exploded view of weapon is for reference only.
Design is subject to change without notice.

REV #013020



For any warranty issues or claims, **DO NOT** ship the i
 KelTec's service department. Furthermore **DO NOT** s
 approved BATF form.

- 102 HINGE
- 105 WASHER
- 404 LOCKNUT WASHER
- 406 FOREND NUT
- 612 STEEL BAFFLES
- 613 ALUMINUM BAFFLES
- 614 END CAP
- 616 BARREL TUBE
- 617 FOREND LOCK
- 619 LOCK SPRING
- 621 OUTER TUBE (EXCHANGE ONLY)
- 625 HANDGUARD
- N001 M3 NUT
- S041 M3 X 30 SHS
- W007 O RING

NOTE:
 Parts shown are exclusive parts for the CQB model SUB2000.

Additional Part Change:

The CQB Model ships with SUB2000-552 Brass Bolt, replacing SUB2000-152-Bolt.

SUB-2000-617 AND 619, replace SUB-2000-158-Rear Sight.

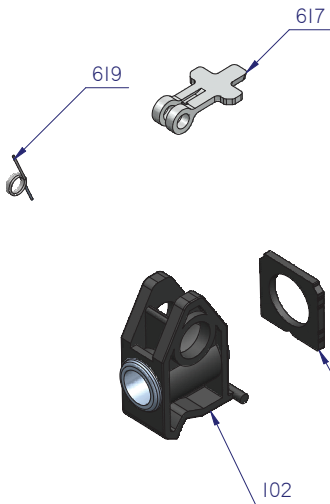
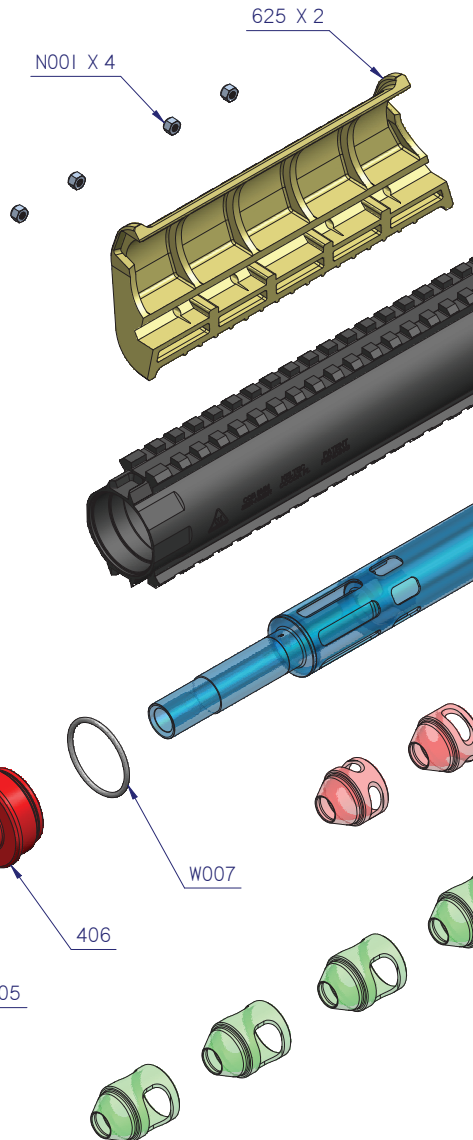

Item without first contacting
Ship without a copy of the

SUB2000[®] CQB

EXCLUSIVE PARTS

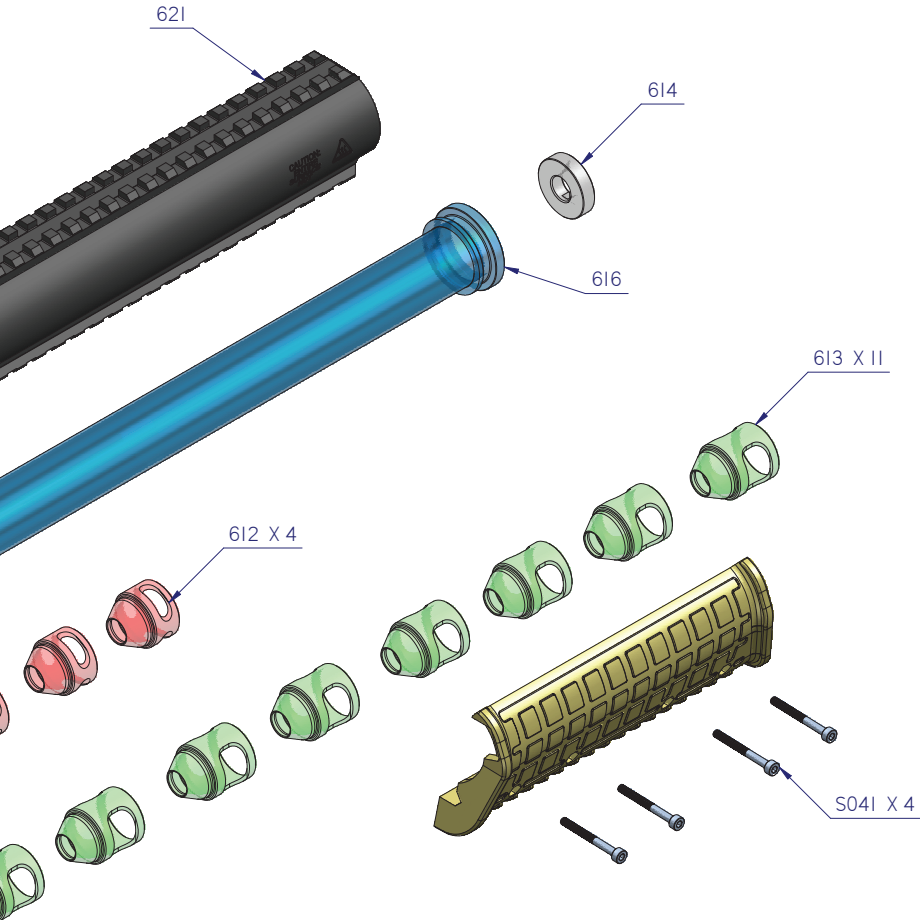

NOTE:
Exploded view of weapon is for reference only.
Design is subject to change without notice.

NOTES

KELTEC[®]



1505 Cox Rd Cocoa FL 32926
p: 800.515.9983 f: 321.631.1169
e: info@keltecweapons.com



KELTECWEAPONS.COM